

Safety Information

1. Manuals Provided with This Machine

2. Safety Information for This Machine

3. Other Information for This Machine

For information not found in paper manuals, see the online manuals available on our web site (<http://www.ricoh.com/>) or via the control panel.



Read this manual carefully before you use this machine and keep it handy for future reference. For safe and correct use, be sure to read the Safety Information in this manual before using the machine.

TABLE OF CONTENTS

How to Read the Manuals.....	1
1. Manuals Provided with This Machine	
Manuals for This Machine.....	2
2. Safety Information for This Machine	
The Meanings of the Safety Symbols Used with This Machine.....	3
The Meanings of Safety Labels.....	4
Safety Precautions to Be Followed.....	4
Safety Labels of This Machine.....	8
3. Other Information for This Machine	
Laws and Regulations.....	11
Legal Requirements.....	12
Trademarks.....	13

How to Read the Manuals

Symbols Used in the Manuals

This manual uses the following symbols:

★ Important

Indicates points to pay attention to when using the machine, and explanations of likely causes of paper misfeeds, damage to originals, or loss of data. Be sure to read these explanations.

↓ Note

Indicates supplementary explanations of the machine's functions, and instructions on resolving user errors.

[]

Indicates the names of keys on the machine's display or control panels.

 **Region A** (mainly Europe and Asia), (mainly Europe), or (mainly Asia)

 **Region B** (mainly North America)

Differences in the functions of Region A and Region B models are indicated by two symbols. Read the information indicated by the symbol that corresponds to the region of the model you are using. For details about which symbol corresponds to the model you are using, see "Model-Specific Information", Specifications.

Disclaimer

To the maximum extent permitted by applicable laws, in no event will the manufacturer be liable for any damages whatsoever arising out of failures of this machine, losses of the registered data, or the use or non-use of this product and operation manuals provided with it.

Make sure that you always copy or have backups of the data registered in this machine. Documents or data might be erased due to your operational errors or malfunctions of the machine.

In no event will the manufacturer be responsible for any documents created by you using this machine or any results from the data executed by you.

Notes

Contents of this manual are subject to change without prior notice.

The manufacturer shall not be responsible for any damage or expense that might result from the use of parts other than genuine parts from the manufacturer with your office products. For good output quality, the manufacturer recommends that you use genuine toner from the manufacturer.

Some illustrations in this manual might be slightly different from the machine.

Colors on color keys or the color circle may differ slightly from the colors of actual copies.

The color samples in this manual may differ slightly from the colors of actual copies.

Certain options might not be available in some countries. For details, please contact your local dealer.

Depending on which country you are in, certain units may be optional. For details, please contact your local dealer.

Manuals for This Machine

The operating instructions of this machine are provided in the following formats:

Format	Manuals
Printed manual	<ul style="list-style-type: none"> • Safety Information
CD-ROM	<ul style="list-style-type: none"> • Driver Installation Guide
Manuals displayed on the control panel	<ul style="list-style-type: none"> • User Guide (Full Version) (HTML)
Web pages	<ul style="list-style-type: none"> • Safety Information • User Guide (Selected Version) (PDF) • User Guide (Full Version) (HTML) • Driver Installation Guide

Safety Information

Before using the machine, be sure to read the section of this manual entitled Safety Information. It also describes each regulation and environmental conformance.

User Guide (Selected Version)

Regarding the basic usage of this machine, frequently used functions, troubleshooting when an error message appears, etc., summaries are provided for each user manual.

User Guide (Full Version)

Describes the setup for using the machine, how to use functions to copy, fax, print, scan or for maintenance and specifications, troubleshooting, system settings, and security functions.

Manuals are available in English, German, French, Italian, Spanish, Dutch, and Russian.

The User Guide for languages other than shown above contains the information in User Guide (Selected Version) and Security.

Driver Installation Guide

Describes how to install and configure each driver. This manual is included in the drivers CD.

Note

- Before you configure the extended security and authentication settings, refer to "Registering Administrators Before Using the Machine" in the Security.
- Using the machine's security function prevents unauthorized use of the machine, data tampering, or information leakage. For enhanced security, we recommend that you first make the following settings:
 - Install the Device Certificate.
 - Enable SSL (Secure Sockets Layer) Encryption.
 - Change the user name and password of the administrator.

- You can download information about the machine's certification, which is based on an IT security certification system (hereafter CC Certification), from the following URL:

U.S. Government Protection Profile for Hardcopy Devices Version 1.0 (IEEE Std 2600.2™-2009)









- IM C2000/C2500/C3000/C3500
For Administrator: https://support.ricoh.com/services/device/ccmanual/im_C2000_C2500_C3000_C3500/en/download_admin.html
For User: https://support.ricoh.com/services/device/ccmanual/im_C2000_C2500_C3000_C3500/en/download_user.html
- IM C4500/C6000
For Administrator: https://support.ricoh.com/services/device/ccmanual/im_C4500_C5500_C6000/en/download_admin.html
For User: https://support.ricoh.com/services/device/ccmanual/im_C4500_C5500_C6000/en/download_user.html

Protection Profile for Hardcopy Devices 1.0 dated September 10, 2015

- IM C2000/C2500/C3000/C3500/C4500/C6000
For Administrator: https://support.ricoh.com/services/device/ccmanual/im_C2000_C2500_C3000_C3500_C4500_C5500_C6000/en/download_admin.html
For User: https://support.ricoh.com/services/device/ccmanual/im_C2000_C2500_C3000_C3500_C4500_C5500_C6000/en/download_user.html

This information is about how to set up the machine. If you have purchased a CC Certified machine, be sure to read it before operating the machine so you can make the correct settings before using it.

The Meanings of the Safety Symbols Used with This Machine

	Prohibition
	Caution
	General mandatory action sign
	Keep out of reach of children
	Do not touch
	Do not throw into the fire
	Do not use the cleaner
	Caution, risk of having hands or arms caught
	Caution, hot surface

The Meanings of Safety Labels



Indicates a potentially hazardous situation which, if instructions are not followed, could result in death or serious injury.



Indicates a potentially hazardous situation which, if instructions are not followed, may result in minor or moderate injury or damage to property.

Safety Precautions to Be Followed

Requirements for Locating and Installing Machines



- Avoid taking the following actions close to or inside this machine because doing so can result in fire or electric shock:
 - Using flammable sprays, solvents, and so on
 - Placing flammable sprays, solvents, and so on
 - Placing containers holding liquids or small metal objects



- Do not place the machine in a humid or dusty environment. Doing so can result in fire or electric shock.
- Do not place the machine on an unstable or tilted surface. Doing so can cause the machine to fall or topple over, possibly resulting in injury.
- Do not obstruct the machine's vents. Doing so can result in fire as the internal components are overheated.
- Do not place heavy objects on the machine. Doing so can cause the machine to fall or topple over, possibly resulting in injury.
- When using this machine in a poorly ventilated or narrow room continuously for a long period of time or printing a high volume of materials, make sure to ventilate the room sufficiently.

Requirements for Using Power Plugs and Cords



WARNING

- Avoid taking the following actions because doing so can result in fire or electric shock:
 - Using any power supply voltage or frequencies other than those that match the specifications shown
 - Using multi-socket adaptors
 - Using extension cords
 - Touching the prongs of the power cable's plug with anything metallic

- Avoid applying the following actions to power cords because doing so can result in fire or electric shock:
 - Damaging them
 - Bundling them
 - Modifying them
 - Putting heavy objects on them
 - Pulling them forcibly
 - Bending them forcibly

- Do not handle the power cord plug with wet hands. Doing so can result in electric shock.

- The supplied power cord or cords are for use with this machine only. They cannot be used for appliances other than this machine. Also, do not use power cords other than the power cord or cords supplied with this machine. Doing so can result in fire or electric shock.

- To prevent fire or electric shock, disconnect the plug and the power cord from the wall outlet at least once a year and check them. If any of the following conditions exist, do not use the plug and the power cord continuously, and consult your dealer or service representative.
 - There are burn marks on the plug
 - The prongs on the plug are deformed
 - The power cord's inner wires are exposed or broken
 - The power cord's coating is cracked, dented, or damaged
 - When the power cord is bent, the power turns off and on
 - Part of the power cord becomes hot

CAUTION

- When disconnecting the power cord from the wall outlet, make sure to pull the plug, not the cord. Do not pull the power cord forcibly. Doing so can damage the power cord, possibly resulting in fire or electric shock.

- Be sure to push the power cord plug fully into the wall outlet. Also, do not push it into loose and unstable wall outlets likely to cause a contact failure. Doing so can result in heat generation.

- Be sure to disconnect the plug from the wall outlet and clean the prongs and the area around the prongs at least once a year. Allowing dust to build up on the plug constitutes a fire hazard.

- If you do not use the machine for a long period of time such as consecutive holidays, be sure to disconnect the power cord plug from the wall outlet for reasons of safety.

- When performing maintenance on the machine, disconnect the power cord from the wall outlet for safety.

- Power Source
220–240 V, 10 A, 50/60 Hz

Requirements during Emergencies



WARNING

- Do not touch this machine if a lightning strike occurs in the immediate vicinity. Doing so could result in electric shock.

- Be sure to install the machine as close as possible to a wall outlet so that you can disconnect the power cord plug easily in an emergency.

- If the machine behaves unusually as follows, turn off the power immediately. After turning off the power, make sure to disconnect the power cord plug from the wall outlet, and then contact your service representative and report the problem. Continuously using the power cord can result in fire or electric shock.
 - The machine is emitting smoke
 - The machine is emitting odors
 - Metal objects or other foreign objects have fallen inside the machine
 - Water or other fluids have fallen inside the machine

WARNING

- If the machine topples or a cover or other part is damaged, turn off the power immediately. After disconnecting the power cord plug from the wall outlet. Contact your service representative. Using the machine continuously can result in fire or electric shock.

Requirements for Relocating Machines



CAUTION

- When moving the machine, do not hold the control panel. Doing so may damage the control panel and can result in injury or malfunction.
- When moving the machine with the optional paper tray unit attached, do not push the upper part of the main unit forcibly. Doing so can cause the main unit to detach from the optional paper tray unit, possibly resulting in injury.
- When carrying or moving the machine by lifting it for relocation to another floor, contact your service representative. Dropping or toppling the machine can result in injury or malfunction.
- After moving the machine, use the caster fixture to fix it in place. Otherwise, the machine might move or topple over to cause injury.
- When moving the machine, make sure to unplug the power cord from the wall outlet and confirm that line cords and other connecting cables have been removed. Otherwise, the power cord is damaged, possibly resulting in fire or electric shock.

Requirements for Using the Machine



CAUTION

- Do not look into the light source. Doing so may damage your eyes.
- If the first or second layer paper tray is installed, do not pull out more than one tray at a time. Pressing down forcefully on the machine's upper surface might cause the machine to topple over, possibly resulting in injury.
- Do not use stapled sheets of paper, aluminum foil, carbon paper, or any kind of conductive paper. Doing so can result in fire.
- Keep SD cards and USB flash memory devices out of reach of children. If a child accidentally swallows an SD card or USB flash memory device, consult a doctor immediately.
- When lowering the ADF, do not place your hands on the hinges and exposure glass. Your hands or fingers are caught, which can result in injury.

Requirements for Handling the Machine's Interior



WARNING

- Do not remove any covers or screws other than those explicitly mentioned in this manual. There are high voltage components inside the machine that can cause electric shock. Also there are laser components inside the machine that can cause blindness. Contact your sales or service representative if any of the machine's internal components require maintenance, adjustment, or repair.
- Do not disassemble or modify this machine. Doing so can result in fire and electric shock. Also, exposure to the laser components inside this machine risks blindness.

CAUTION

- There are highly-heated parts inside the machine. When removing misfed paper, do not touch areas other than those specified in this manual. Touching those areas can result in burns.

CAUTION

- There are parts inside the machine that may break when touched. When removing misfed paper, do not touch connectors, sensors, and LED specified in "Troubleshooting". Touching them can result in malfunction.
- Although the machine is designed so that a safety device protects users from injury, take care not to touch the rollers during operation. The rollers may pinch before stopping completely.
- Contact your sales or service representative for cleaning the machine's interior. If the machine's interior is not regularly cleaned while dust accumulates, fire and malfunction can result.
- When replacing paper or removing jammed paper, make sure not to trap or injure your fingers.
- When operating the machine, do not put your hand inside the booklet finisher tray of the finisher's staple unit. You may trap your fingers in the machine's gap and injury can result.

Requirements for Handling Supplies



WARNING

- Do not store toner (new or used) or toner containers while toner is inside in a place with an open flame. The toner can ignite and result in burns or fire.
- The following explains the warning messages on the plastic bag used in this product's packaging:
 - Do not leave the polythene materials (bags, etc.) supplied with this machine close to babies and small children. Suffocation can result if polythene materials are brought into contact with the mouth or nose.
- Do not dispose of the following items into a fire. Toner will ignite on contact with naked flame and burns can result.
 - Toner (new or used)
 - Toner containers while toner is inside
 - Toner-attached parts
- Do not absorb spilled toner (including used toner) using a vacuum cleaner. Absorbed toner may cause ignition or explosion due to electric contact sparks inside the vacuum cleaner. However, you can use a toner-compatible industrial vacuum cleaner. When toner is spilled, remove the spilled toner using a wet cloth so that the toner is not scattered.



CAUTION

- Do not open toner containers forcibly while toner is inside, crush or squeeze them. Toner spillage can cause accidental ingestion or dirtying of clothes, hands, or floor.
- Do not leave the following items in a place where children can reach them:
 - Toner (new or used)
 - Toner containers while toner is inside
 - Toner-attached parts
- When removing jammed paper, replenishing or replacing toner (new or used), make sure not to inhale toner.
- When the following occurs while toner is handled, receive emergency measures first, and then consult a doctor if necessary.
 - When inhaling toner, gargle with a large amount of water and move into a fresh air environment.
 - When swallowing toner, dilute gastric contents with a large amount of water.
 - When getting toner into your eyes, flush them with a large amount of water.
- When removing jammed paper, replenishing or replacing toner (new or used), be careful not to have toner dirt your skin or clothes.
- If toner (new or used) comes into contact with your skin or clothes and smears them, take the following actions:
 - If toner comes into contact with your skin, wash the affected area thoroughly with soap and water.
 - If toner comes into contact with your clothes, wash the stained area with cold water. Heating the stained area by applying hot water will set the toner into the fabric and removing the stain may become impossible.
- When replacing a container with toner (including used toner) or consumables with toner, be careful that the toner does not splatter. After removing used consumables and shutting the lid of the container if the lid is available, put them in a bag.

Safety Labels of This Machine

Positions of WARNING and CAUTION labels

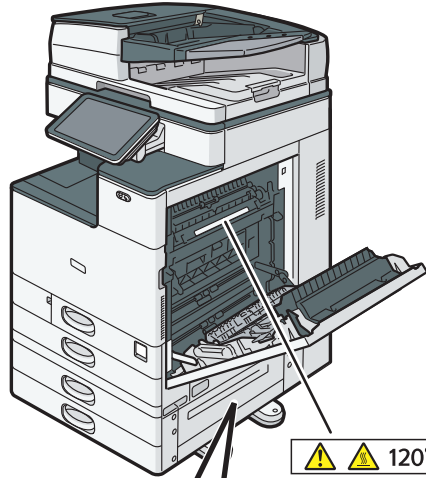
This machine has labels for ⚠ WARNING and ⚠ CAUTION at the positions shown below. For safety, please follow the instructions and handle the machine as indicated.



⚠ ⚠ 120°C ⚠ CAUTION ACHTUNG ATTENTION ATTENZIONE PRECAUCIÓN
 注意高温 高温注意 고온주의 高温注意

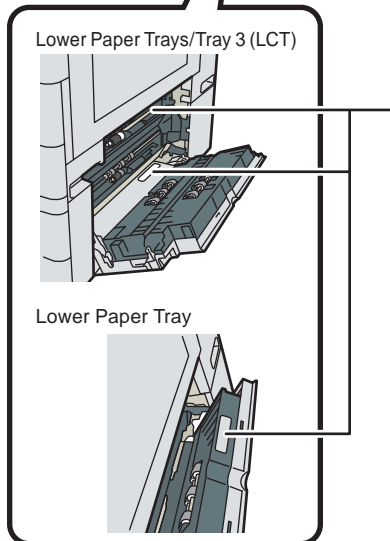

Do not touch the parts a label indicates. The inside of the machine could be very hot. Caution should be taken when removing misfed paper.

The inside of the machine could be very hot. Do not touch the parts which a label is put on. Otherwise, an injury might occur.

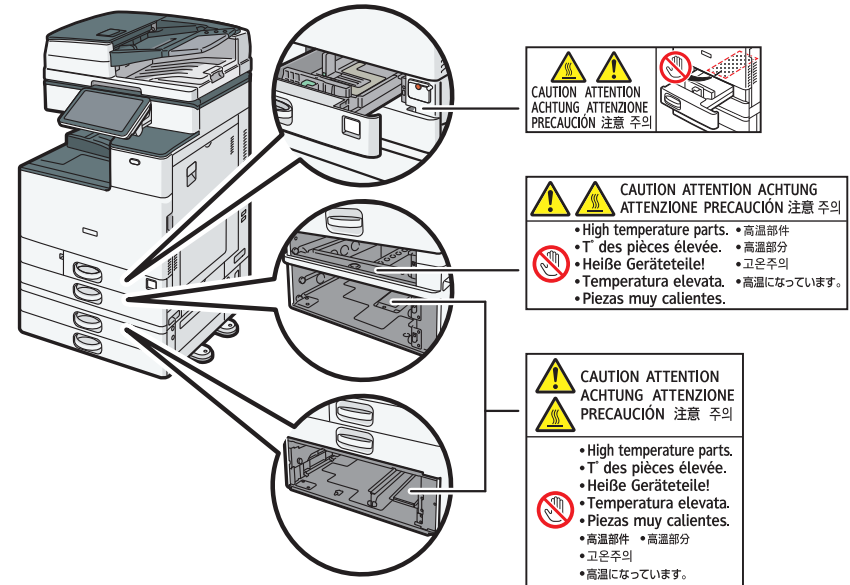

⚠ ⚠ CAUTION ATTENTION
 ACHTUNG ATTENZIONE
 PRECAUCIÓN 注意 주의

⚠ ⚠ CAUTION ATTENTION ACHTUNG
 ATTENZIONE PRECAUCIÓN 注意 주의

- High temperature parts. • 高温部品
- T des pièces élevée. • 高温部分
- Heiße Geräteteile! • 고온주의
- Temperatura elevata. • 高温になっています。
- Piezas muy calientes.

⚠ CAUTION ATTENTION
 ACHTUNG ATTENZIONE
 PRECAUCIÓN 注意 주의

- High temperature parts.
- T des pièces élevée.
- Heiße Geräteteile!
- Temperatura elevata.
- Piezas muy calientes.
- 高温部品 • 高温部分
- 고온주의
- 高温になっています。

Finisher SR3260 or Booklet Finisher SR3270

The diagram shows the machine with various safety callouts. A callout on the left shows a hand near a roller with a warning icon and a 'no touch' symbol. A callout at the top right shows a hand near a hot part with a warning icon and a 'no touch' symbol. Two callouts in the middle show internal views of the Finisher SR3260 and Booklet Finisher SR3270 with a warning icon and a 'no touch' symbol. A callout at the bottom left shows a hand near a hot part with a warning icon and a 'no touch' symbol. A callout at the bottom right shows a hand near a protruding part with a warning icon and a 'no touch' symbol.

During operation, rollers for transporting the paper revolve. Take care not to touch rollers during operation. Otherwise, an injury might occur.

The inside of the machine could be very hot. Do not touch the parts which a label is put on. Otherwise, an injury might occur.

Finisher SR3260 Booklet Finisher SR3270

The inside of the machine could be very hot. Do not touch the parts which a label is put on. Otherwise, an injury might occur.

Keep your hands clear of the booklet finisher tray when pulling out or pushing in the finisher's staple unit, or removing paper jam. You might trap your fingers if you do not.

Finisher SR3280 or Booklet Finisher SR3290

The diagram shows the machine with various safety callouts. A callout on the left shows a hand near a roller with a warning icon and a 'no touch' symbol. A callout at the top right shows a hand near a hot part with a warning icon and a 'no touch' symbol. A callout in the middle shows a hand near a hot part with a warning icon and a 'no touch' symbol. A callout at the bottom left shows a hand near a hot part with a warning icon and a 'no touch' symbol. A callout at the bottom right shows a hand near a protruding part with a warning icon and a 'no touch' symbol.

During operation, rollers for transporting the paper revolve. Take care not to touch rollers during operation. Otherwise, an injury might occur.

The inside of the machine could be very hot. Do not touch the parts which a label is put on. Otherwise, an injury might occur.

The inside of the machine could be very hot. Do not touch the parts which a label is put on. Otherwise, an injury might occur.

Keep your hands clear of the booklet finisher tray when pulling out or pushing in the finisher's staple unit, or removing paper jam. You might trap your fingers if you do not.

Be careful of the protruding parts of the front cover when replacing the cartridge in the saddle stitch unit or clearing a paper jam from the saddle stitch unit.

Internal Finisher SR3300

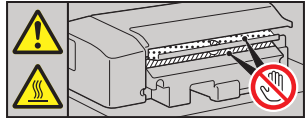

The inside of the machine could be very hot. Do not touch the parts which a label is put on. Otherwise, an injury might occur.

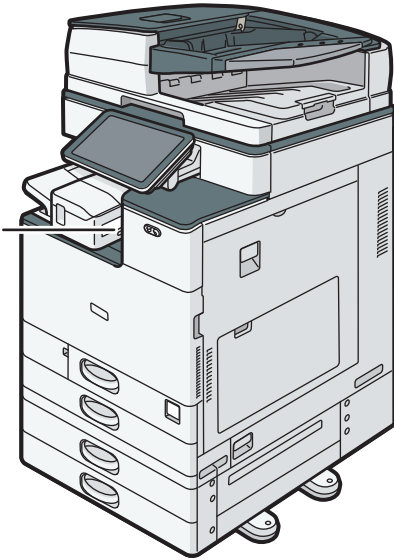

ARDF

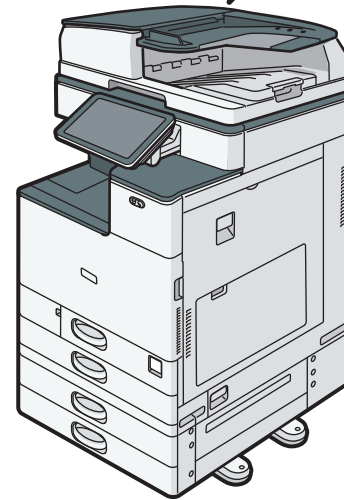
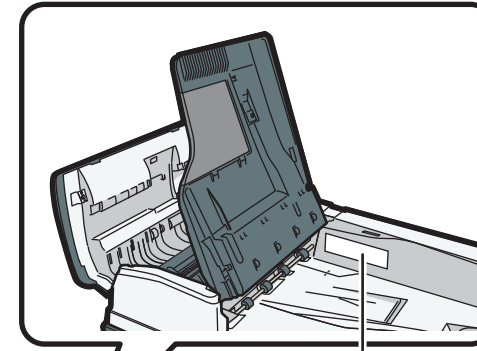

The cartridge may become hot during use. Do not touch the cartridge immediately; turn off the main power of the machine and wait 20 minutes or more before replacing it.

Large capacity tray (LCT)

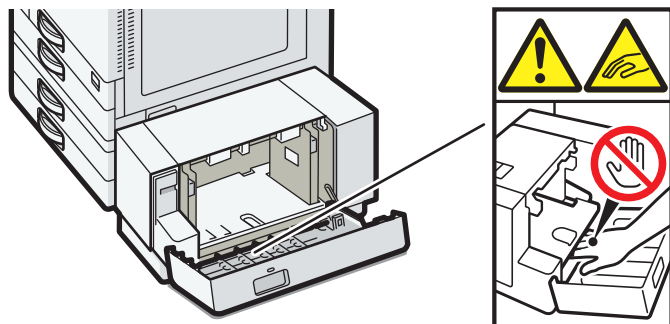

Do not place your hand under the bottom plate. Doing so may result in your fingers becoming trapped in the gap and injured.

Laws and Regulations

Duplication and Printing Prohibited

Do not copy or print any item for which reproduction is prohibited by law.

Copying or printing the following items is generally prohibited by local law:

bank notes, revenue stamps, bonds, stock certificates, bank drafts, checks, passports, driver's licenses.

The preceding list is meant as a guide only and is not inclusive. We assume no responsibility for its completeness or accuracy. If you have any questions concerning the legality of copying or printing certain items, consult with your legal advisor.

Symbols for Earth, Insulation, and Power Switch

Symbols for earth, insulation, and power switch that are used for this machine are as follows:

- ⊕ : Protective earth
- ↓ : Earth
- I : POWER ON
- ⏻ : STANDBY

Legal Requirements

Laser Safety

For IM C2000/C2500/C3000/C3500

This machine complies with the requirements of IEC 60825-1:2014 for class 1 laser product. The machine contains four AlGaInP laser diodes, 655–663 nanometer wavelength for each emitter. The beam divergence angle is 21 degrees (minimum) and 29 degrees (maximum) in the vertical direction, and 7 degrees (minimum) and 11 degrees (maximum) in the horizontal direction, and laser beams are generated in Continuous Wave (CW) mode. The maximum output power of the light source is 10 milliwatt.

The following label is attached on the rear side of the machine:



Caution

Use of controls or adjustments or performance of procedures other than those specified in this manual might result in hazardous radiation exposure.

For IM C4500/C6000

This machine complies with the requirements of IEC 60825-1:2014 for class 1 laser product. The machine contains four 4ch-Laser Diode Arrays (4ch-LDA). Laser diodes are AlGaInP, 657–663 nanometer wavelength for each emitter. The beam divergence angle is 16 degrees (minimum) and 25 degrees (maximum) in the vertical direction, and 7 degrees (minimum) and 13 degrees (maximum) in the horizontal direction, and laser beams are generated in Continuous Wave (CW) mode. Each 4ch-LDA has four light sources and the maximum output power of the light source is 17 milliwatt.

The following label is attached on the rear side of the machine:



Caution

Use of controls or adjustments or performance of procedures other than those specified in this manual might result in hazardous radiation exposure.

EMC Directive

Installing the Ferrite Core

Attach a ferrite core to the following cables to prevent RF interference:

- An Ethernet interface cable connecting to the Device Server Option port
- A telephone line cable connecting to the G3 interface connector
- A telephone line cable connecting to the Extra G3 interface unit connector
- An USB cable connecting to the card reader
- The antenna cable of the Wireless LAN interface board

User Information on Electrical and Electronic Equipment (For Users in India)

This product including components, consumables, parts and spares complies with the "India E-waste Rule" and prohibits use of lead, mercury, hexavalent chromium, polybrominated biphenyls or polybrominated diphenyl ethers in concentrations exceeding 0.1 weight % and 0.01 weight % for cadmium, except for the exemptions set in the Rule.

NOTICE TO USERS (NEW ZEALAND)

- The grant of a Telepermit for any item of terminal equipment indicates only that Telecom has accepted that the item complies with minimum conditions for connection to its network. It indicates no endorsement of the product by Telecom, nor does it provide any sort of warranty. Above all, it provides no assurance that any item will work correctly in all respects with another item of Telepermitted equipment of a different make or model, nor does it imply that any product is compatible with all of Telecom's network services.
- This equipment is not capable, under all operating conditions, of correct operation at the higher speeds for which it is designed. Telecom will accept no responsibility should difficulties arise in such circumstances.
- Devices connected to the telephone port may lose their memory if this fax machine is on line for extended periods. To prevent this, such devices should have the facility for battery or similar backup of memory.
- This device may be subject to ringing or bell tinkle when certain other devices are connected to the same line. If this occurs, the problem should not be referred to the Telecom Faults Service.
- This equipment should not be used under any circumstances that may constitute a nuisance to other Telecom customers.

- Telepermitted equipment only may be connected to the auxiliary telephone port. The auxiliary telephone port is not specifically designed for 3-wire connected equipment that may not respond to incoming ringing when attached to this port.

Trademarks

The SD is a trademark of SD-3C, LLC.

Other product names used herein are for identification purposes only and might be trademarks of their respective companies. We disclaim any and all rights to those marks.



EN **AU**

D0BQ-7052



Operating Instructions

Mopria Guide

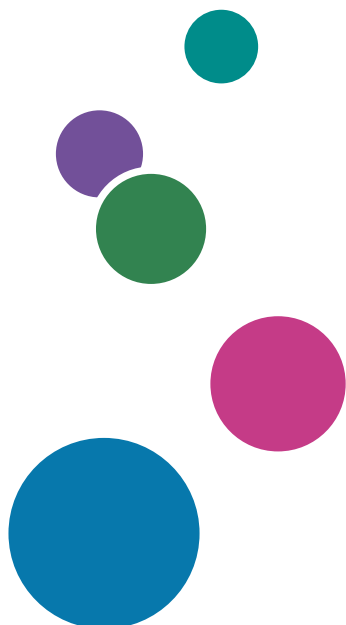

For safe and correct use, be sure to read Safety Information before using the machine.

TABLE OF CONTENTS

Introduction.....	2
Meanings of Symbols.....	2
Disclaimer.....	2
Preparations.....	3
Connecting the Machine and an Android Device on the Same Network.....	3
Confirming the Settings on the Machine.....	3
1. Using Mopria Print	
About Mopria Print Service.....	5
Setting Up an Android Device.....	6
Printing.....	7
2. Using Mopria Scan	
About the Mopria Scan Application.....	9
Setting Up an Android Device.....	10
Using the Scanner Function.....	12
Confirming/Changing Settings.....	14
3. Supplement	
Troubleshooting.....	17

Introduction

Meanings of Symbols

This manual uses the following symbols:

Important

Indicates points to pay attention to when using functions. This symbol indicates points that may result in the product or service becoming unusable or result in the loss of data if the instructions are not obeyed. Be sure to read these explanations.

Note

Indicates supplementary explanations of the product's functions and instructions on resolving user errors.

[]

Indicates the names of keys or buttons on the product or display.

Disclaimer

To the maximum extent permitted by applicable laws, in no event will the manufacturer be liable for any damages whatsoever arising out of failures of this product, losses of documents or data, or the use or non-use of this product and operation manuals provided with it.

Make sure that you always copy or have backups of important documents or data. Documents or data might be erased due to your operational errors or malfunctions of the machine. Also, you are responsible for taking protective measures against computer viruses, worms, and other harmful software.

In no event will the manufacturer be responsible for any documents created by you using this product or any results from the data executed by you.

Some illustrations in this manual might be slightly different from the machine.

The versions of Mopria applications used in this manual's description are as follows.

The actual screen may vary depending on the version of the application you are using.

- Mopria Print Service: 2.5.5
- Mopria Scan: 1.0.5

Preparations

To use the Mopria Print Service and the Mopria Scan application, you need to configure the settings on both the machine and the Android device.

Connecting the Machine and an Android Device on the Same Network

Connect the machine and your Android device with one of the following methods. For details about the connection procedure, see the instruction manuals provided with the machine or your Android device.

- Connecting directly on a wireless LAN network (Wi-Fi)
- Connecting over an access point (You can connect the machine and the access point on a wireless LAN network or a wired LAN network.)

Confirming the Settings on the Machine

To use the Mopria Print Service and the Mopria Scan application, the machine's settings need to be as shown below. Confirm these settings.

Setting item	Setting values for using Mopria	How to confirm using your web browser (Web Image Monitor) ^{*1}
User Authentication Management	Disabled (Factory-set value: Disabled)	<ol style="list-style-type: none">1. Log in to Web Image Monitor as a device administrator.2. Click [Device Management] → [Configuration], in this order.3. Click [User Authentication Management] in [Device Settings], and confirm that [User Authentication Management] is disabled. If it is enabled, switch it to disabled.
IPP	Enabled (Factory-set value: Enabled)	<ol style="list-style-type: none">1. Log in to Web Image Monitor as a network administrator.2. Click [Device Management] → [Configuration], in this order.3. Click [IPv4] in [Network], and confirm that [IPP] is enabled. If it is disabled, switch it to enabled.
Bonjour	Enabled (Factory-set value: Enabled)	<ol style="list-style-type: none">1. Log in to Web Image Monitor as a network administrator.2. Click [Device Management] → [Configuration], in this order.3. Click [Bonjour] in [Network], and confirm that [IPv4] or [IPv6] for [Bonjour] is enabled. If it is disabled, switch it to enabled.

* 1 The procedures in this manual may be different for some versions of Web Image Monitor. If the procedures are different, see the instruction manual provided with the machine or the Web Image Monitor Help.

1. Using Mopria Print

This section explains how to use the Mopria Print Service to print on the machine from an Android device.

About Mopria Print Service

The machine supports the Mopria Print Service.

You can easily print on the machine by using the Mopria Print Service over a wireless network from an Android device. You do not need to install a printer driver specifically for the machine on your Android device.

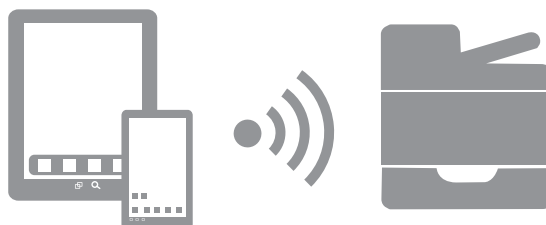

DTN753

For details about the Mopria Print Service, see the following URL.

<https://mopria.org/how-to-print>

↓ Note

- If the operating system in your Android device is Android 8 or 9, you can use the "Default Print Service", which is pre-installed on the operating system. For the differences between the Default Print Service and Mopria Print Service, see <https://mopria.org/android-8-9-faq>.

Setting Up an Android Device

1

You can set up an Android device to use the Mopria Print Service.

- 1. If the Mopria Print Service is not installed on your Android device, install it.**

Search for Mopria Print Service at the Google Play store, and install it.

- 2. Open the Android settings screen and tap [Printing].**

- 3. Tap [Mopria Print Service].**

- 4. Turn the service on.**

If a message appears, confirm the information and tap [OK].

Mopria authorized devices on the same network are automatically discovered, and then shown in a list.

When the name of the machine appears, the setup is complete.

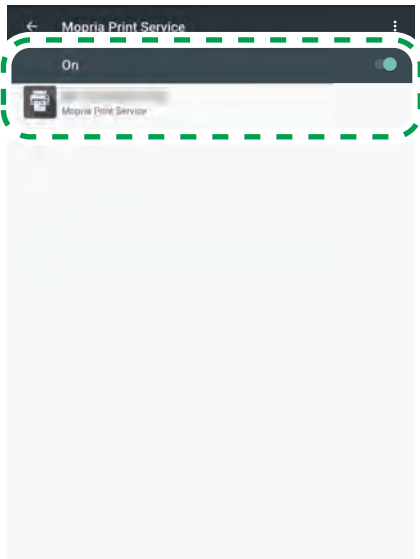

DYR526

Printing

You can use the Mopria Print Service to print from an Android device.

★ Important

- The Mopria Print Service cannot accept multiple jobs at the same time. When the first job is finished, print the next job.

1. Open the page you want to print on your Android device.
2. Select [Print], [Share], or another menu to open the [Mopria Print Service] screen (the screen in step 3).

The names of menus and operational procedures vary depending on the type of application.

After you tap [Print], [Share], or another menu, if a [Mopria Print Service] icon (🖨️) or [Print] icon (🖨️) appears, tap that icon.

3. Perform the next operation in the [Mopria Print Service] screen.

1. Select an output printer. To change the output location, tap ▼, and then select a location from the list.
2. To change the printing conditions, such as the number of copies, paper size, one-sided/two-sided printing, etc., tap ▼, and then change the settings.
3. Tap the [Print] icon (🖨️).

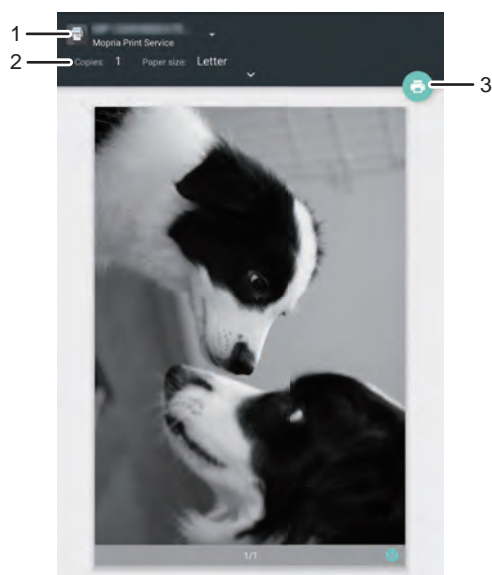

DYR527

Printing starts.

2. Using Mopria Scan

This section explains how to use the Mopria Scan application to use the machine's scanner function from an Android device.

About the Mopria Scan Application

2

The machine supports the Mopria Scan application.

You can easily use the machine's scanner function over a wireless network from an Android device. You do not need to install a scanner driver specifically for the machine on your Android device.

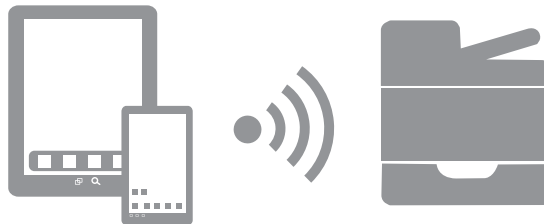

DTN753

For details about the Mopria Scan application, search for Mopria Scan at the Google Play store.

Setting Up an Android Device

You can set up an Android device to use the Mopria Scan application.

1. If Mopria Scan is not installed on your Android device, install it.

Search for Mopria Scan at the Google Play store, and install it.

2. Start the Mopria Scan application.

2

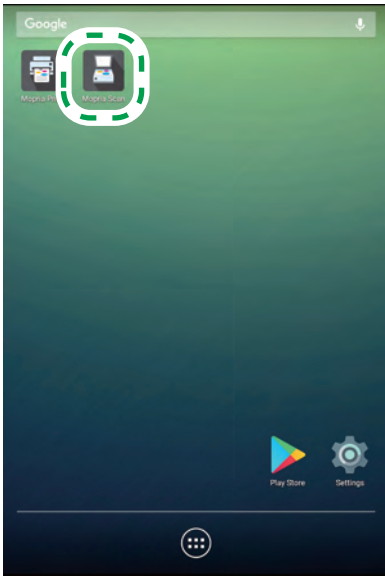

DYR528

Mopria authorized devices on the same network are automatically discovered, and then shown in a list.

When the name of the machine appears, the setup is complete.

3. If you cannot find the machine, tap [ADD SCANNER MANUALLY].

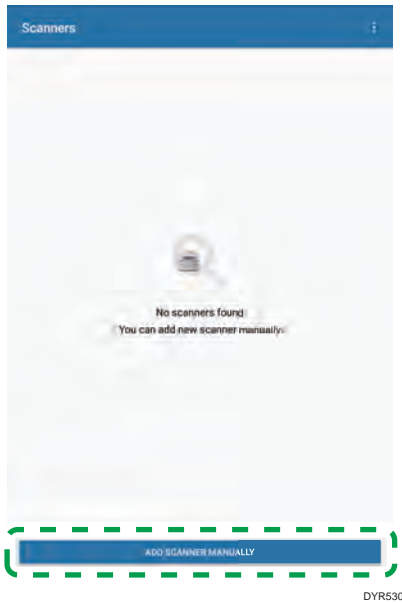

The information input screen appears.



4. Input the information for the machine, and then tap the confirmation icon (✓), in the upper right.

The machine's information is registered.

Using the Scanner Function

You can use the Mopria Scan application to scan from an Android device.

★ Important

- You cannot use the Mopria Scan application's scanner function when personal authentication or user code authentication is set on the machine and users are restricted.

1. Place the original on the machine.
2. Start the Mopria Scan application from an Android device, and then select the machine.

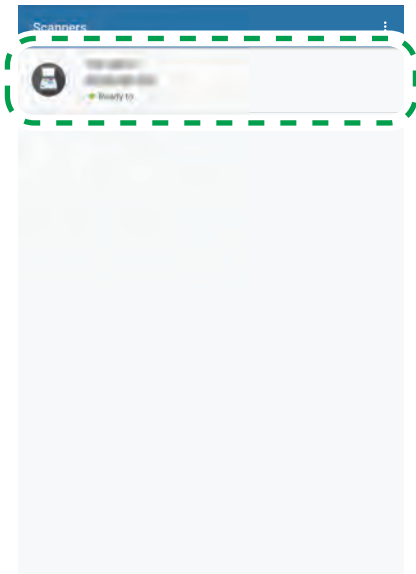

DYR529

3. If necessary, set the scanning conditions, and then tap [SCAN].

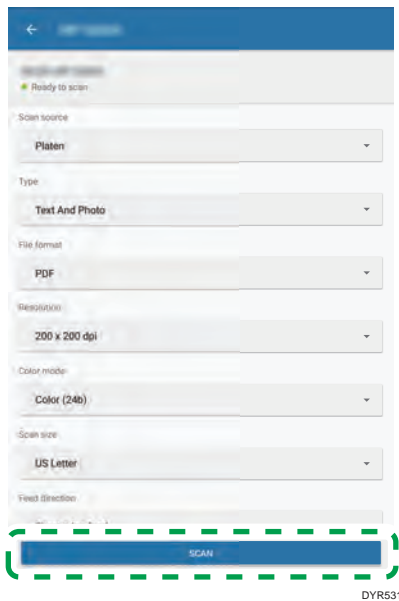

The scanned image is saved to the Android device.

Note

- You can use the Mopria Scan application's scanner function even if [Use a Destination List that is not DSM] is set to [Not Available] on the [General Settings] tab in [Scanner Features] on the machine.
- The following settings are applied when an original is scanned using the Mopria Scan application. The settings in the [Send Settings] tab in [Scanner Features] on the machine are not applied.
 - [Compression (Black & White)]: On
 - [Compression Method (Black & White)]: MMR
 - [Compression (Gray Scale / Full Color)]: On ([Off] is applied when [Color mode] is set to [Color (24b)] and [File format] is set to [TIFF] in the Mopria Scan application.)
- If the application you are using in the Android device is not compatible with the file format of the image scanned with the Mopria Scan application, you may not be able to open the image properly. Use an application that is compatible with the file format of the scanned image.

Confirming/Changing Settings

Confirm the Mopria Scan application's settings, and then if necessary, you can change them.

1. Start the Mopria Scan application.

2

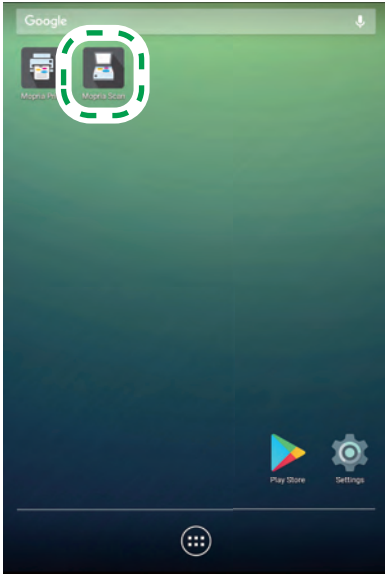

DYR528

2. Tap the menu icon () in the upper right.
3. Tap [Settings].



DYR532

The settings screen appears.

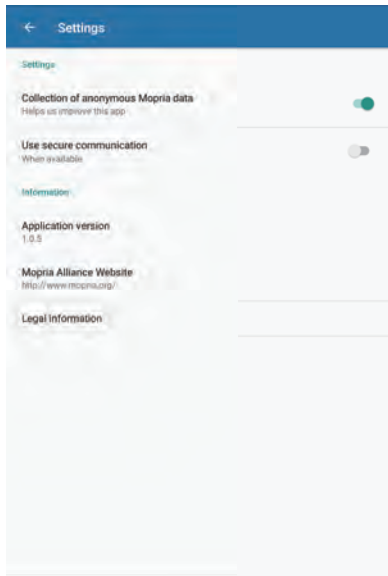

4. Confirm the settings, and change them as needed.

3. Supplement

Troubleshooting

This section explains what to do if you have trouble with your Android device's setup, printing, or scanning.

Condition	Cause	Solution
The name of the machine does not appear (the machine is not discovered automatically) when doing setup, printing, or scanning on your Android device.	The following causes are possible. <ul style="list-style-type: none">• The machine's power is not turned on.• The machine and the Android device cannot connect to the same network.• The Mopria Print Service is disabled on the Android device.	Use the following solution that corresponds to the cause. <ul style="list-style-type: none">• Turn on the power to the machine.• Confirm that the machine and Android device can connect to the same network. For details, see page 3 "Connecting the Machine and an Android Device on the Same Network".• Enable the Mopria Print Service on the Android device. For the setting procedure, see Steps 2 to 4 in page 6 "Setting Up an Android Device". If you still cannot print or scan, even after applying the solutions, redo the setup.

There is also an FAQ in the Mopria Print Service Help. Display the Mopria Print Service Help by tapping [Mopria Print] on the list of applications screen on your Android device.



Mopria and the Mopria logo are trademarks of Mopria Alliance Inc.

Android and Google Play are registered trademarks or trademarks of Google Inc.

Wi-Fi is a registered trademark of the Wi-Fi Alliance®.

Other product names used herein are for identification purposes only and might be trademarks of their respective companies. We disclaim any and all rights to those marks.

MEMO

MEMO

MEMO



Notes for Users

This machine supports AirPrint.

AirPrint is a function allowing you to use print/scanner/fax functions* from AirPrint-compatible machines on the same network (wired or wireless) with iOS and Mac OS, for which you do not need to install any software and/or driver on iOS and Mac OS.

*Functions that can be used vary depending on the installed option (fax unit).

For more information about AirPrint, please visit: <https://support.apple.com/kb/HT4356>.

Conditions to use AirPrint functions

AirPrint functions can be used when the following settings are enabled on the MFP/printer:

- AirPrint settings are enabled (factory default: Active)
- IPP settings are enabled (factory default: Active)
- Bonjour settings are enabled (factory default: Active)
- IP settings used for SSL communication are enabled (factory default: Active)
- TLS1.2 settings are enabled (factory default: Active)
- A device certificate (self-signed certificate) for SSL/TLS communication is installed (factory default: Installed)

To confirm the settings, see "Confirming Active Settings for the Functions" and "Confirming the IPP-SSL Settings".

Warnings/restrictions

■ General functions

- When the AirPrint function is enabled and the device certificate for SSL/TLS communication has not been installed, a device certificate (self-signed certificate) is automatically installed.
- If the device certificate for SSL/TLS communication has been installed, communication with the following utility may not be established.
 - Streamline NX
 - GlobalScan NX
 - Embedded Software Architecture applications

*No support is provided depending on the model you are using.

If this is the case, communication with these utilities may be restored using either of the three methods below:

 - Install the certificate issued by the certificate authority on both of the machine and the utility.
 - If the device certificate (self-signed certificate) has already been installed on the machine, install the certificate on the utility as a Trustworthy Certificate.
 - First disable the AirPrint function, and then delete the device certificate for SSL/TLS communication (If the device certificate is deleted, no AirPrint function can be used.)
- The default for [Permit SSL/TLS Communication] is [Ciphertext/Cleartext]. When [Ciphertext/Cleartext] is specified, http access will not automatically switch to https access, so it is necessary to specify "https" to use encrypted communication. For instance, when accessing Web Image Monitor, you need to enable https to specify a URL in the address bar in the browser.
- If [Permit SSL/TLS Communication] is set to [Ciphertext/Cleartext], communication may be in cleartext with device management software provided by Ricoh even if the certificate for SSL/TLS communication is installed. To use encrypted communication, it is necessary to change the setting to [Ciphertext Priority] or [Ciphertext Only].
- AirPrint can be used on the AirPrint-compatible printer on the same network (wired or wireless) with iOS and Mac OS. Also it can be used when connected via a USB cable with devices installed with Mac OS. Connect a USB 2.0 interface cable (USB Type-B connector) to the USB 2.0 interface (USB Type-B connector) of the device, and then connect it to the USB terminal of the device installed with Mac OS.

■ Print function

- When printing using AirPrint, configure the settings without using the user authentication management function or set the printer job authentication to [Simple(All)]. For details, refer to "Verifying Users to Operate the Machine (User Authentication)", Security in the manual included with the main unit.
- When printing with AirPrint, multiple jobs cannot be accepted at a time. After printing a current job, proceed to print the next job.
- Even though a print job for text and covers is canceled, the text may be printed anyway.
- When duplex printing is specified for print data that ends on an odd-numbered page, depending on the application or OS, a blank page may be automatically added. The blank page automatically added is counted as a black-and-white page.

■ Scanner function

- Even if [Not Available] is selected in [Use a Destination List that is not DSM] of [General Settings] under [Scanner Settings], you can scan documents with AirPrint.
- When scanning is performed with AirPrint, the following settings are enabled. Settings in [Send Settings] under [Scanner Settings] on the machine are not enabled.
 - [Compression (Black & White)]: On
 - [Compression Method (Black & White)]: MMR
 - [Compression (Gray Scale / Full Color)]: On

❖ The scanner function cannot be used when:

- Available functions are restricted through the user authentication management function

■ Fax function

- The name of the sender will be the one used for [First Name] specified for [Program Fax Information] in [Initial Settings] in [Fax Settings]. For details, refer to "Registering and Changing the Sender Information", Fax.
*When using a name other than the one used for [First Name], contact your service representative.
- To send faxes, characters that cannot be used in destinations are ignored.
- The default of fax transmission line is set to "outside line". When faxing to an extension number, contact your service representative.
- You can check the transmission result by displaying the communication management report/transmission results.
- You cannot check the contents of the faxes sent with AirPrint on the machine.
- On OS X 10.8, a cover sheet is not sent even if a cover sheet is specified.

❖ The fax function cannot be used when:

- Available functions are restricted through the user authentication management function
- The fax function is restricted through the external charge unit
- [Restrict Use of Destinations (Fax)] is set to [On]
- A fax unit is not installed
- A fax header is not set on the machine when the country code is set to Korea
- The fax function is used on the main unit
Send faxes again when the fax job is complete.
- The hard disk drive of the main unit is full
Delete the documents stored on the machine.

Confirming Active Settings for the Functions

1. Log in to Web Image Monitor as a network administrator.
Refer to "Logging in to Web Image Monitor ", Introduction and Basic Operations.
2. Click [Device Management] > [Configuration].
3. Click [AirPrint] in [Network].
4. Check that [AirPrint] is set to [Active].
Unless [Active] is selected, select it.
5. Click [OK].
6. Click [IPv4] in [Network].
7. Check that [IPP] is set to [Active].
Unless [Active] is selected, select it.
8. Click [OK].
9. Click [Bonjour] in [Network].
10. Check that either of [IPv4] or [IPv6] in [Bonjour] is set to [Active].
Unless [Active] is selected, select it.
11. Click [OK].

Confirming the IPP-SSL Settings

1. Log in to Web Image Monitor as a network administrator.
Refer to "Logging in to Web Image Monitor ", Introduction and Basic Operations.
2. Click [Device Management] > [Configuration].
3. Click [Device Certificate] in [Security].
4. Check the status of "Certificate 1".
 - Confirm that "Certificate Status" is set to "Installed".
 - Check "Validity Period" and confirm that the certificate is unexpired.
5. Click [OK].
6. Click [SSL/TLS] in [Security].
7. Check the items below and configure proper settings.
 - The version of the Internet protocol used for SSL/TLS is set to [Active].
 - [TLS1.2] in [SSL/TLS Version] is set to [Active].
8. Click [OK].

If you cannot establish a connection by using the procedure above, contact your service representative.



AirPrint and the AirPrint logo are trademarks of Apple Inc.



手差し部品交換後の注意事項

本紙が同梱されている手差し部品の交換後は、手順に従いキャリブレーションを実施してください。

➤ 実施しない場合、サイズ誤検知による用紙ミスフィードが発生します。

補足：手差し主走査長さ検知センサを交換した際にキャリブレーションが必要となります。

<作業手順>

1. 同梱のキャリブレーション治具 [A] を手差しトレイの溝に合わせてセットし、サイドフェンスを治具幅に合わせる。(治具幅：138mm)

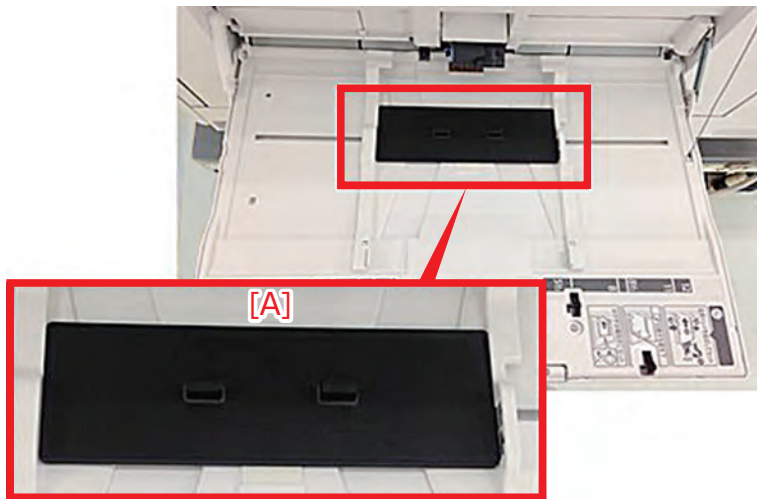

2. SP1-008-032 (手差しサイズ検知設定 調整実行) を実行する。
3. SP1-008-033 (手差しサイズ検知設定 調整結果) を確認し、1：成功 になっていることを確認する。

Required Procedure after Replacing the By-pass Tray

Follow the procedure below after replacing the By-pass tray.

➤ Failure to carry out this procedure may lead to paper jams caused by a paper size detection error.

Note : This procedure is required when replacing the By-pass width sensor.

<PROCEDURE>

1. Place the included reference block [A] on the By-pass tray. Move the side fences until they touch the reference block, as shown in the above photo. (Reference block size: 138mm)
2. Execute SP1-008-032 (Bypass Size Detection Adj. Main Scan Size Adj.).
3. Check SP1-008-033 (Bypass Size Detection Adj. Main Scan Adj. Result), and confirm the value is “1: Success”

© 2018

Printed in China

JA (JP) EN (GB) 2018年6月 D0BQ-4581



D0BQ4581

廢トナーボトル交換手順書

Waste Toner Bottle

安全に正しくお使いいただくために、操作の前には必ず『安全上のご注意』をお読みください。廃トナーボトルは交換表示が出るまで使用できます。交換表示が出たあとに交換してください。

For safe and correct use, please be sure to read Safety Information before replacing the machine's supplies.

Für einen sicheren und korrekten Gebrauch lesen Sie bitte unbedingt die Sicherheitshinweise, bevor Sie die Verbrauchsmaterialien des Geräts austauschen.

Pour une utilisation correcte et en toute sécurité, veuillez consulter les Consignes de sécurité avant de remplacer les consommables de l'appareil.

Per un uso corretto e sicuro, leggere le Informazioni sulla sicurezza prima di sostituire i consumabili della macchina.

Para un uso correcto y seguro, lea la Información de seguridad antes de sustituir los consumibles de la máquina.

Lees voor veilig en correct gebruik de Veiligheidsinformatie vóórdat u verbruiksartikelen van het apparaat vervangt.

Для безопасного и правильного использования устройства ознакомьтесь с информацией по безопасности перед заменой его принадлежностей.

Para uma utilização segura e correta, certifique-se de que lê as Informações de Segurança antes de substituir os consumíveis do equipamento.

Per tal de fer un ús correcte i segur, llegiu la Informació sobre seguretat abans de substituir els consumibles de la màquina.

A biztonságos és megfelelő használat érdekében kérjük, olvassa el a Biztonsági tudnivalókat a készülék kellékanyagainak cseréje előtt.

Emniyetli ve doğru kullanım için lütfen makinenin sarf malzemelerini değiştirmeden önce Güvenlik Bilgilerini mutlaka okuyun.

Aby zapewnić bezpieczne i prawidłowe użytkowanie należy przed wymianą materiałów eksploatacyjnych w urządzeniu przeczytać informacje dotyczące bezpieczeństwa.

Varmista turvallinen ja oikea käyttö lukemalla turvallisuustiedot ennen laitteen tarvikkeiden vaihtoa.

Για σωστή και ασφαλή χρήση, παρακαλώ βεβαιωθείτε ότι έχετε διαβάσει τις Πληροφορίες Ασφαλείας πριν αντικαταστήσετε τα αναλώσιμα του μηχανήματος.

För en säker och korrekt användning, läs igenom säkerhetsinformationen innan du byter material i maskinen.

Husk at læse Sikkerhedsoplysninger for sikker og korrekt brug, inden du udsifter tilbehør til maskinen.

For sikker og riktig bruk bør du lese sikkerhetsinformasjonen før du bytter maskinrekvisita.

Pro bezpečné a správné používání zařízení si před výměnou spotřebního materiálu přečtěte Bezpečnostní informace.

Para um uso seguro e correto, certifique-se de ler as Informações de segurança antes de substituir os suprimentos do equipamento.

为了安全并正确使用，请确保在更换机器配件前阅读《安全信息》。

為了能安全及正確地使用本機，請務必閱讀「安全資訊」一節，然後再更換機器的耗材。

안전하고 올바른 사용을 위해 기기 소모품을 교체하기 전에 안전 정보를 반드시 읽으십시오.

เพื่อความปลอดภัยและการใช้อย่างถูกต้อง

โปรดมั่นใจว่าได้อ่านข้อมูลเพื่อความปลอดภัยก่อนที่จะเปลี่ยนวัสดุสิ้นเปลืองของเครื่อง

للاستخدام الآمن والصحيح، يرجى التأكد من قراءة معلومات السلامة قبل استبدال مستلزمات الماكينة.

1

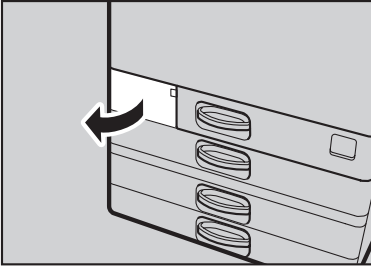

EBE001

2

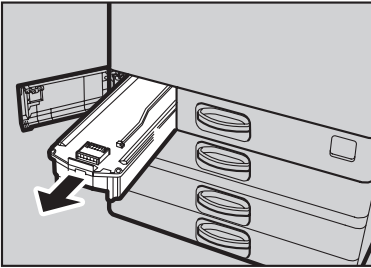

EBE002

3

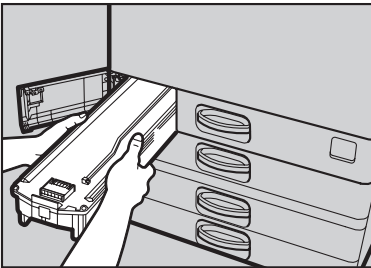

EBE003

4

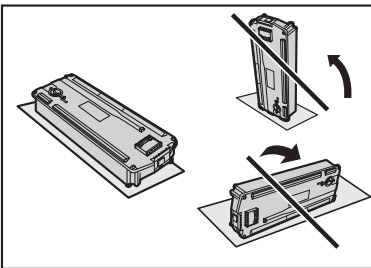

EBE004

5

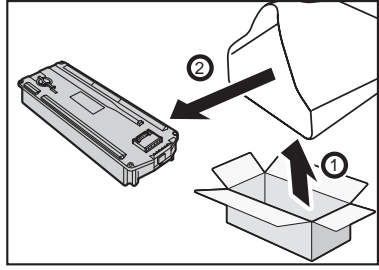

EBE005

6

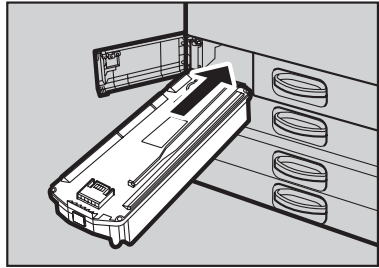

EBE006

7

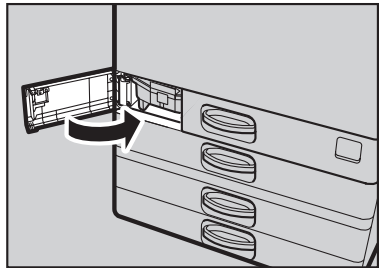

EBE007

8

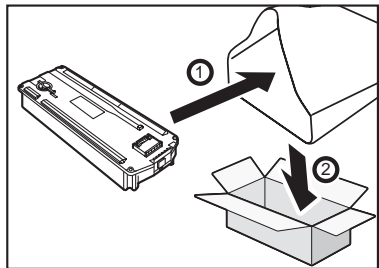

EBE008

EN (GB) EN (US) EN (AU) DE (DE) FR (FR) IT (IT) DA (DK) ES (ES)
 NL (NL) NO (NO) PT (PT) PT (BR) FI (FI) SV (SE) CA (ES) CS (CZ)
 HU (HU) PL (PL) TR (TR) EL (GR) RU (RU) JA (JP) ZH (CN) ZH (TW)
 TH (TH) AR (AR)

© 2018 Printed in China D0BQ-7128A



D0BQ7128A

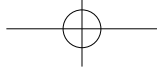

For Users in People's Republic of China



D0BQ7086

请妥善保管，切勿遗失

产品中有有害物质使用限制的描述

1 产品中有有害物质的名称及含量

耗材	产品名称：Waste Toner Bottle IM C6000		品种代码：418425			
	有害物质					
部件名称	铅 (Pb)	汞 (Hg)	镉 (Cd)	六价铬 (Cr(VI))	多溴联苯 (PBB)	多溴二苯醚 (PBDE)
1 碳粉	—	—	—	—	—	—
2 载体	—	—	—	—	—	—
3 电气元件	—	—	—	—	—	—
4 金属	×	○	○	○	○	○
5 树脂	○	○	○	○	○	○

备注

本表格依据 SJ/T 11364 的规定编制。

○：表示该有害物质在该部件所有均质材料中的含量均在 GB/T 26572 规定的限量要求以下。
 ×：表示该有害物质至少在该部件的某一均质材料中的含量超出 GB/T 26572 规定的限量要求。
 —：本产品不含此部件。

2 环保使用期限的说明



仅适用中国的
环保使用期限

这个标志是在中国销售的电子信息产品适用的环保使用期限。

只要遵守有关该产品的安全和使用时的注意事项，从生产日期开始的年限内，不会出现环境污染，不会给人体和财产带来严重影响。而且，那是根据安全使用期限法算出的。

© 2018
Printed in China
ZH (CN)
D0BQ-7086